

PLAN

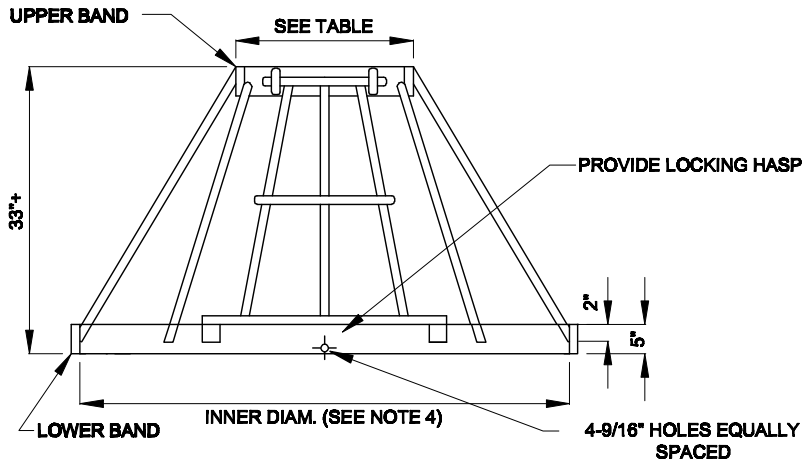

ELEVATION

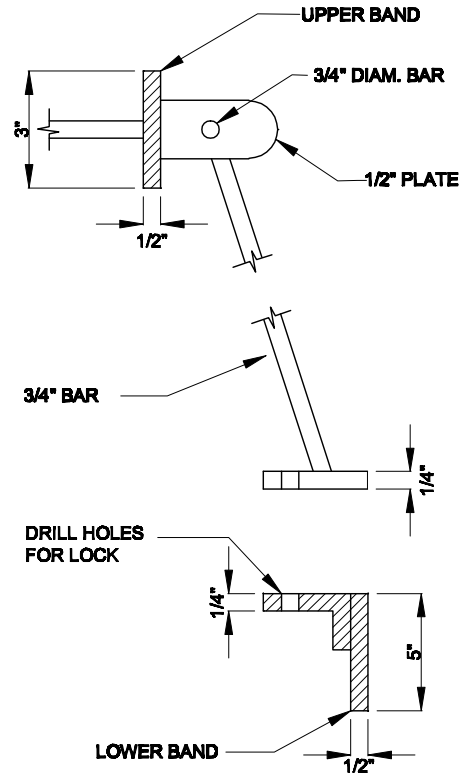

ENTRY GATE DETAIL

| MH | UPPER BAND OUTER DIAMETER |
|-------------|------------------------------|
| 48",54",60" | 36" |
| 72" | 42" |
| 96" | 42" |

BAND DIAMETER TABLE

NOTES:

1. ALL STEEL IN PLATES, BARS AND BANDS SHALL CONFORM TO THE REQUIREMENTS OF ASTM A36.
2. STEEL DEBRIS CAGE SHALL BE HOT-DIP GALVANIZED IN ACCORDANCE WITH ASTM A123 (AASHTO M111) AFTER FABRICATION.
3. ALUMINUM IS AN OPTIONAL CAGE MATERIAL.
4. COVER BAND DIMENSIONS TO MATCH STRUCTURE.

| | | | |
|---|--|--|--------------------|
|  | <p>City of Bremerton</p> <hr/> <p>PUBLIC WORKS</p> | <p>DEBRIS CAGE</p> | <p>4015</p> |
| <p>DESIGN/CONSTRUCTION STANDARDS</p> | <p><small>Alteration of this drawing is prohibited. Any approval of an altered drawing is unauthorized and void.</small></p> | <p><small>Revision Date</small></p> <p>2/5/07</p> | |